

DISTRIBUTED MANAGEMENT OF SCIENTIFIC PROJECTS

An Analysis of Two Computer Conferencing Experiments at NASA.

by

Jacques Vallée
Senior Research Fellow
Institute for the Future
2740 Sand Hill Road
Menlo Park, California 94025

Bradford Gibbs
Chief, Communications Branch
NASA-Ames Research Center
Moffett Field, California 94035

ABSTRACT

Between August 1975 and March 1976, two NASA projects with geographically separated participants used a computer conferencing system developed by the Institute for the Future for portions of their work. We collected monthly usage statistics for the system in order to examine the group and individual participation patterns for all conferences. We also coded the entries according to five content categories: learning, procedural, social, substantive, and administrative. We further analyzed the conference transcripts to derive several observations about the use of the medium. This analysis suggests that the medium can be used to: (1) integrate the communications activity into the workday, (2) provide precision and timeliness of information, (3) replace other media, (4) support other media, (5) handle emergency situations, (6) promote an effective management style, and (7) extend communications beyond working hours.

These conferences also provided an opportunity to evaluate the attitudes of users and the costs of computer conferencing. An independent evaluation of the attitudes of participants in the transportation conference revealed that users found the medium best suited to narrowly defined tasks involving the exchange of technical information. Six cost components were taken into consideration: terminal equipment, communication with a network port, network connection, computer utilization, data storage, and administrative overhead. These costs are expected to be substantially reduced in the future. However, training and facilitation are the key to cost-effective use of the medium and to successful teleconferencing in general.

DISTRIBUTED MANAGEMENT OF SCIENTIFIC PROJECTS

An Analysis of Two Computer Conferencing Experiments at NASA

The National Aeronautics and Space Administration began using computer conferencing for the first time in August 1975, when a series of teleconferencing experiments between the Ames Research Center and the Institute for the Future were begun. The Institute made available to NASA its PLANET-1 computer conferencing system, which operates on the network of Tymshare, Inc. This system allows people who are geographically separated to engage in group planning and information retrieval, either by agreeing in advance to a particular "meeting" time or simply by running the program at their convenience to review each other's comments.

THE MEDIUM

Let us assume that you are a participant in one of the experimental conferences organized by NASA. You have access to a computer terminal, and the organizer has indicated that the conference is open. The first time you enter, PLANET-1 asks you to type your last name and a personal password. This password may consist of any three letters or numbers and is needed to prevent others from reading private messages that are sent to you or from making entries under your name. If you are registered in only one conference, you are automatically placed in that conference. However, if you are registered in more than one conference, PLANET prints the title of each of them and asks you to choose which one you wish to enter. (An asterisk indicates those conferences in which new entries have been made since you last participated.) PLANET then prints an informational heading and the full title of the conference you select as well as a list of participants. Finally, it tells you if anyone else is present at that moment and prints all the messages that have been made since you last entered, notifying you when you are up to date. For example:

[6] Masy 18-Nov-75 11:57 PM

Good morning. Welcome to the mini-conference. As the chairman, I will try to keep the discussion moving so that we can cover all of the agenda topics. We will start promptly at 9:30 AM, PDT and end at 11:30. Although we should limit our private messages, they can

be used as well as anonymous messages when it is considered in the best interest of the mini-conference. An agenda of today's mini-conference follows momentarily.

You are up to date.

Once you are in a conference, you can make an entry at any time, even if someone else is already typing. As you type, PLANET automatically assigns a number to your entry, prints your name, and then begins displaying the text as you enter it:

[17] Whorf

Concerning the summary, a number of comments are left open-ended. For example, P.3 [of the draft] concerning intercity bus service--what regulatory and political barriers are involved--and don't they go far beyond matters related to vehicle width? Again, bottom P.3, what is the argument to support the notion that less economic regulation could lead to fewer but more profitable carriers?

All messages are sent to you automatically as they are finished. If you are not present, they will be reprinted the next time you enter the activity. In this case, each entry will include the date and time it was started.

PLANET also offers a number of services for experienced users who wish to perform specialized tasks. For example, the STATUS command prints the names of all the participants, the time they last entered, and the last entry they have seen:

(to PLANET)
STATUS (of participants)

NAME	LAST TIME ENTERED	LAST ENTRY SEEN
Wilson	26-Nov-75 8:51 AM	82
Wood	29-Oct-75 2:46 PM	44
Rollins	21-Nov-75 12:15 PM	79
Bartholow	19-Nov-75 9:28 AM	76
Gibbs	Present	82
Spaeth	26-Nov-75 5:15 AM	82
Mascy	25-Nov-75 10:01 AM	80

Other PLANET services allow you to review previous entries, to submit entries into a private computer file, to join another conference, and to leave the PLANET system. There is no limit on the length of an entry or the number of entries in a conference. Once an entry is in the transcript, it cannot be altered, although it can be deleted by the organizer.

THE CONFERENCES

Two separate projects were conducted at NASA using this new medium. The first was a technology assessment of future transportation systems; a group of 13 experts located throughout the country used the system to prepare and critique successive drafts of a joint document dealing with inter- and intracity transportation. For the second project, 15 U.S. principal investigators of experiments with the Communication Technology Satellite (CTS) used PLANET to discuss pre- and postlaunch operations (Figure 1).

The Institute for the Future provided assistance in organizing the conferences, instructing individual participants, and facilitating the various activities. In addition, it collected monthly usage statistics.

1. *The Transportation Conference.* When the conference on Future Transportation Systems began in September 1975, all the participants knew each other. They had worked together for about six months and had recognized a high need for exchange of views among individuals working on the project. The study was jointly conducted by the Ames Office of Planning and Analysis and the Communications Branch to evaluate the concept of computer conferencing in an application involving an ongoing interagency/university/industry assessment of transportation technology.

The objective of the group was to make a series of recommendations concerning research and development for intercity air and ground transportation through the year 2000. Prior to the start of the computer conference, the group met at a conference in Hershey, Pennsylvania, and began circulating drafts of various sections of the report. The purpose of the computer conference, then, was to promote the orderly critique and integration of these documents while keeping face-to-face interaction to a minimum.

Once the conference began, communication among group members rose rapidly. The rate of private message exchange was particularly high, prompted by the existence of two distinct subgroups--government and contractors. The charter under which the group was formed specified that each subgroup would exchange views among its own members in preparing drafts. This mandate encouraged the use of the private mode until integration in

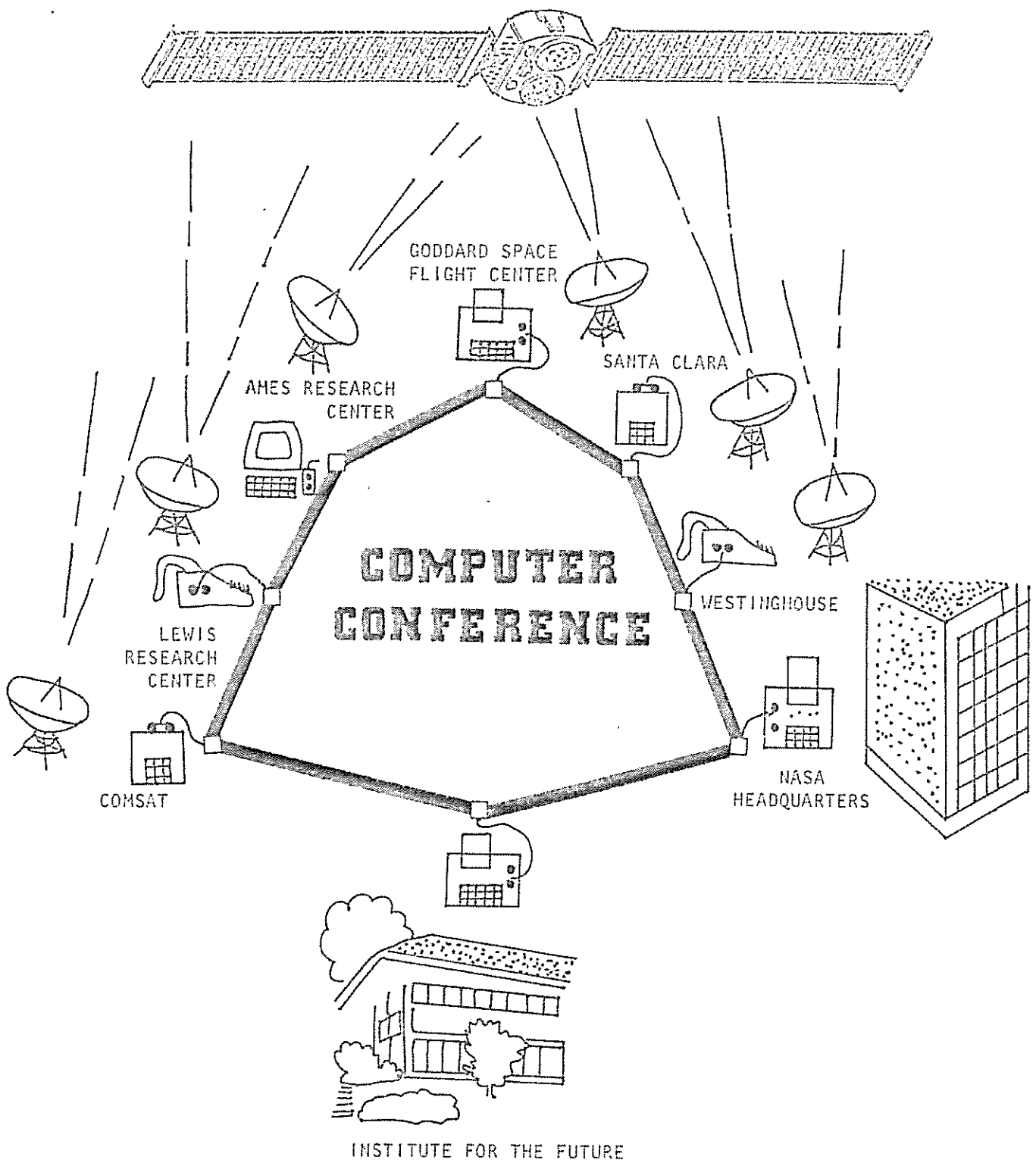

Figure 1. Function of the Computer Conference in the CTS Mission

the public mode could take place. It also led to the creation of a new activity for the exclusive use of government personnel.

On 19 November, the study group conducted a synchronous management meeting over PLANET. Figure 2 shows a "time slice" of this conference which demonstrates the capability for simultaneous message generation by conference participants. On 1 December 1975, the final part of the conference (Part III) was created, and all subconferences which were still in the system were deleted.

2. *The CTS Conference.* The Communications Technology Satellite (CTS) is a joint U.S.-Canadian mission involving government and industry teams in a series of experiments with advanced communications systems. The initial objective of the computer conference was to use this media for such activities as:

- scheduling experiment times
- providing information on the status of spacecraft
- reviewing action items of users' meetings
- planning a teleconference experiment involving four NASA centers

The usefulness of this conference was dramatized by the communications which resulted from successive postponements of the satellite launch date. Some typical entries during this difficult period follow:

[96] Lumb 13-Nov-75 9:15 AM
Hunczak. To answer your questions of yesterday. For experiments 16, 17, and 18, the subcarrier frequencies we have hardware for in the analog FM TV mode are 5.14, 5.36, 5.79, and 6.2 MHZ.

For experiment 16, 17, 18, the ARC transmit frequency is 14.2471666 GHZ.

For experiment 4, the ARC transmit frequency is 14.0521666 GHZ with a 25 MHZ subcarrier service channel.

[97] Kaiser 14-Nov-75 9:00 AM
This one is for whoever from NASA is looking. I am working on the link budget calculations for the tech. managers meeting. I have some of it done; the rest will follow. Kim.

I see from the latest entries that people are watching this.

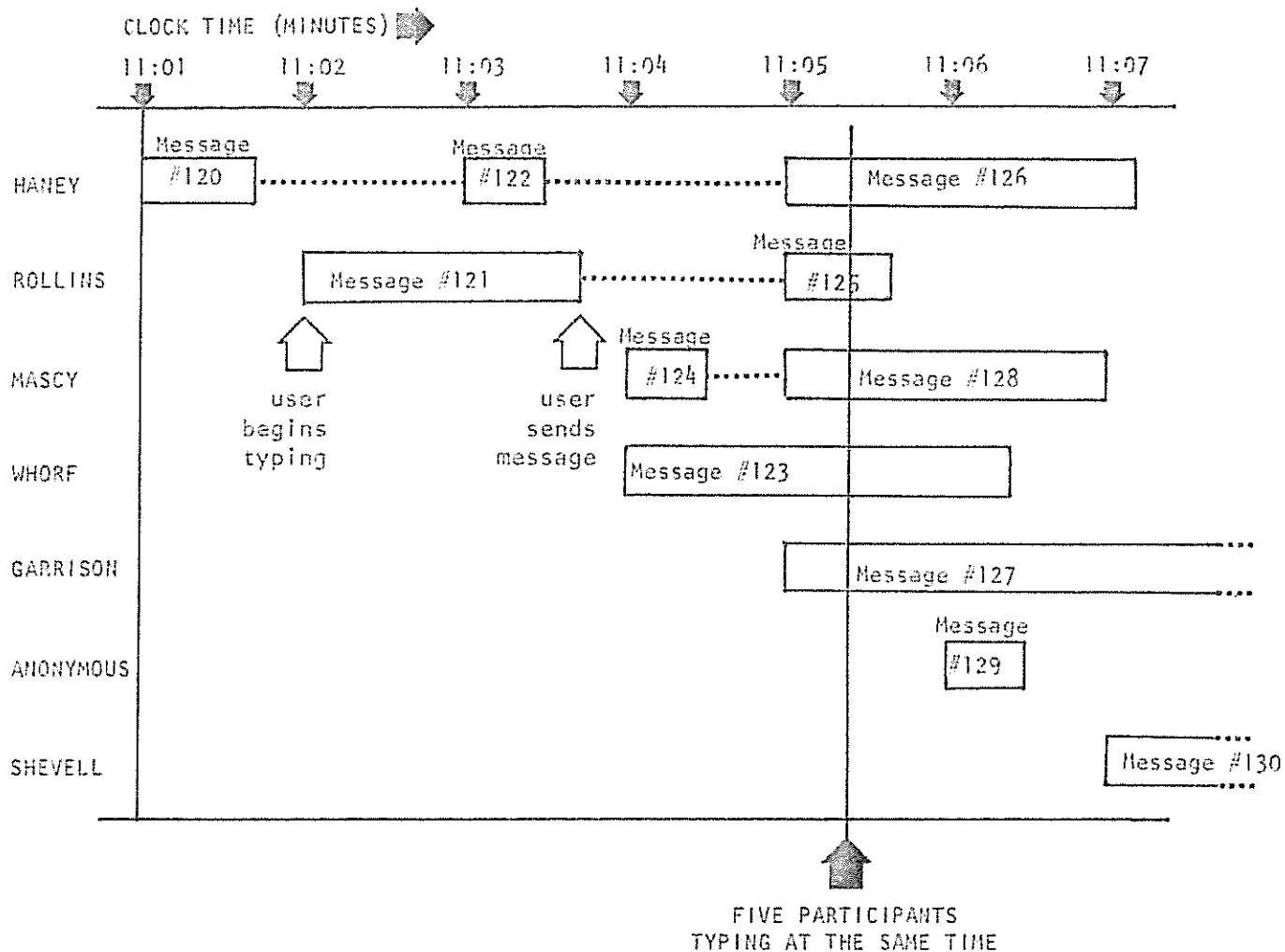

Figure 2. Simultaneous Typing in a Synchronous Conference

Each message is shown here by the times when the author began and stopped typing. Shortly after 11:05, there were five participants typing simultaneously.

[333] Lew 12-Jan-76 2:47 PM

***** To all! *****

In view of the short turn around between the time that the decision is made (anticipated at noon EST, January 13) and a launch as early as 1821 EST, January 16, it is suggested that all PLANET folk check into PLANET on an hourly basis on January 13, 1976, starting at about 1000 EST.

After the launch, it was decided to continue using computer conferencing to more effectively manage the various experiments. In this phase, the discussion took the form of a "collective notepad." Frequent entries broadcast the satellite status and updated experimental schedules to keep the entire group informed. These entries are typified by the following:

[382] Hunczak 27-Jan-76 9:26 AM

CTS mission status. The station acquisition maneuver conducted yesterday to correct the orbit perigee and which changed the S/C drift to 1.54 degrees west (see message 377) was executed on time. S/C location is now slowly approaching its 116 degrees west station. Two maneuvers remain:

1. January 28, 1976 6:56 GMT to 0.37 degrees/day
2. January 29, 1976 6:53 GMT to 0.00 degrees/day on station

Handover of the S/C to Canada will be early in the afternoon (17:00 to 19:00 GMT) on January 29, 1976.

The CTS conference is continuing at the time of this writing.

CONTENT ANALYSIS

In an effort to evaluate the use of the conferencing medium for different tasks, we have coded the public entries made during the conferences into five content categories. These categories include:

1. Learning. Learning entries include all those which are made inadvertently or which deal with the use of the terminal or the software:

[4] Rollins 2-Dec-75 5:17 AM

To Gibbs, Wilson, or anyone who might know: according to the instruction book on PLANET and my earlier experience, PLANET would interface with a CRT terminal (mine is a Tektronix 4012) in a manner which would allow me to copy a page at a time as it came up on the screen. As the machine no longer asks terminal type, I assume that the capability no longer exists?

2. Procedural. An entry which deals with the mode of group interaction, its structure, and its timing is categorized as a procedural entry:

[219] Hall 14-Jan-76 2:10 PM
Is it customary to invite the non-selected proposers? Based on the workshop experience, I don't think it is a good idea.

[22] Masey 3-Dec-75 9:32 AM
Reference message 15, Hall. . . . Re: Dec 9 Comcon. . . . Until 9:30 AM is everyone entering views, critiques, etc. or just Hall? If everyone is entering, then they will need draft material before Dec 9.

3. Social. Social entries include those intended to convey humor, feelings, or a personal statement not directly related to either the medium or the substance of the discussion. There were many examples of this type of entry around the holidays:

[3] Anonymous 1-Dec-75 12:53 PM
Looks like the turkey and stuffing dulled everybody's interest in this system. It's so quiet.

[138] Masey 24-Dec-75 3:27 PM
. . . Gentlemen, I have sincerely enjoyed working with you all thus far. . . . It has been a good year and I look forward to the successful completion of our technology assessment. . . . Have a Merry Christmas. . . . And if I don't see you on the terminal before then . . . have a Happy New Year. . . . Fred

4. Substantive. An entry that deals specifically with the topic of the conference is coded as substantive. Such messages have tended to be much longer than those in other categories, sometimes reaching a page or two in length.

[19] Hall 3-Dec-75 9:25 AM
Re preparations for Dec 4/5 mtg. . . . Draft text has been written for many of the topics in the "A" group of recommendation areas--about 1+ page each. However, we didn't get anywhere with: OMNI rentals, intermodal companies, passenger/freight interactions, role of subsidy, energy sources, or continuing issues research. Hope others will come with ideas on these; otherwise, they go to the "C" group.

5. Administrative. This category deals with the management of the project rather than its research substance. In the transportation conference, most of the substantive material was transmitted through the mail and critiqued in PLANET, which was used to acknowledge receipt of various drafts.

[247] Rollins 20-Jan-76 12:52 PM

To Haney: Where are reports 2, 3, and 4? Were they not supposed to be mailed by Jan 16? What is current schedule for draft report distribution? When will reports 5, 7, and 1 be mailed?

Administrative entries also include those dealing with financial and budgetary reporting:

[57] Hall 11-Dec-75 7:27 PM

To the contractor team. Per discussions last week, let's take another cut at level of effort for study elements. Please report percentage of man-hours in following categories--

1. Planning For and Attending Workshop
2. Issues
3. Technology
4. Scenarios (all types)
5. Evaluation
6. Findings/Recommendations
7. Other

It will be assumed that expenses follow man-hours unless you indicate otherwise.

[59] Hall 11-Dec-75 7:38 PM

To contractor team . . . an administrative matter. . . . Please insure that your next invoice to PMM includes a cumulative total of billings to that point.

Figure 3 shows the distribution on entries by content category in both the Transportation conference and the CTS conference. The percentages of entries in various categories can be compared for these two conferences. Learning and procedural entries are quite similar (9 percent and 8 percent for learning, 24 percent and 19 percent for procedural, respectively). The transportation study, however, involved a higher degree of social activity, which was the smallest of all categories for CTS. The relationship between the two main categories, namely administrative and substantive, was reversed for the two conferences. This reversal could be expected since the transportation group was discussing successive drafts of a substantive report external to the conference, promoting a greater concern for administration, while the CTS group used the computer conference for its substantive work.

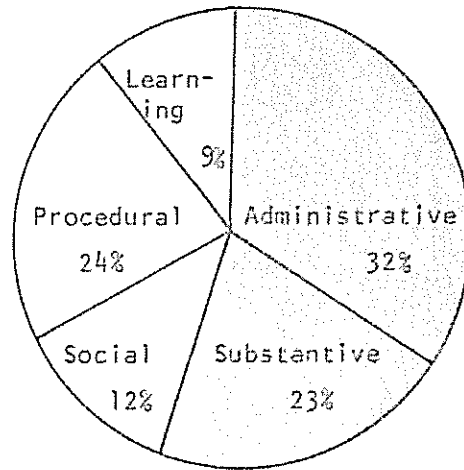

TRANSPORTATION GROUP

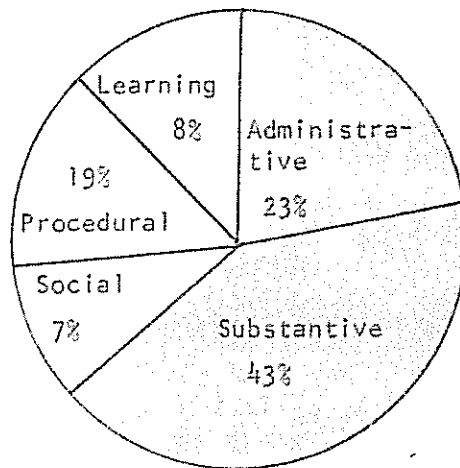

CTS GROUP

Figure 3. Content Categories for the Two NASA Conferences

OBSERVATIONS OF MEDIA USAGE

With the completion of this project, NASA has provided the first large-scale field test of computer conferencing in an operational setting.* Though the project lasted only six months, a review of the transcript provides a basis for making several observations about media usage:

1. Integrating the Communications Activity into the Workday. Researchers in the transportation study adapted their workstyle to the system. One user relied on PLANET to obtain an update early in the morning and late in the afternoon and used the STATUS feature to see who had seen which messages.

2. Providing Precision and Timeliness of Information. Requests for data and updates on the status of the spacecraft or the experiments were crucial to the CTS group. Many entries illustrate this use of the system:

[380] Baker 26-Jan-76 3:22 PM
Is the scheduled time of turning on the beacon (S/C) known at this time? If not, would H. Hunczak please put it on PLANET as soon as it is known? Thanks.

[386] Hunczak 27-Jan-76 1:13 PM
To Baker and all concerned--re message 380: The best estimate of SHF beacon turn-on is February 6, 1976, at approximately 13:00 to 14:00 GMT. If any change occurs, this message will be updated. Good luck.

Entry No. 386 is the response to the request at 380 but is addressed to "Baker and all concerned." Here, the conferencing system is used to keep the whole group informed of the dialogue between two members.

3. Replacing Other Media. The system represented an economical alternative to telephone or telex when information of a technical nature had to be communicated to several people at once:

*Similar field tests are in progress at the U.S. Geological Survey and will result in detailed evaluation; furthermore, other organizations are now undertaking conferencing activities on a scale that promises to be comparable to the NASA effort.

[401] Grayson 30-Jan-76 10:35 AM
Kennard and Chitwood. The subject of a CTS checkout time allocation switch has been agreed between experiment 16 and experiment 20. Chitwood has confirmed this switch for experiment 20. The new schedule should read:

Experiment 20	April 13	1800-1900 GMT
Experiment 16	April 13	1900-2100 GMT

Jerry, please confirm to both Chitwood and myself that you have entered this change in your computer. Thanks to you and experiment 20.

Another user felt that use of PLANET made it possible to keep the group up to date when the thought struck him without resorting to conventional media such as writing letters or making phone calls.

4. Supporting Other Media. In some cases, the system has served to confirm and support information transmitted through other channels, as in this entry:

[458] Hunczak 13-Feb-76 1:09 PM
The spacecraft was ranged by Goddard on February 10. Orbital elements were received at Lewis this morning, processed, and the new S/C ephemeris and AZ-EL angles for your ground sites mailed this afternoon at 20:30, February 13. Would like to know when each receive them in the mail.

The author of this message needs confirmation that a certain document has been received. PLANET thus provided a record of the communications events taking place in the group.

5. Handling Emergency Situations. We have observed instances of reliance on PLANET for crisis management among CTS projects and for decision-making in urgent situations:

[521] Donoughe 4-Mar-76 8:06 AM
To all PIs and experimenters: a problem has developed with the spacecraft. The problem may be in the experiments power converter. All experiments are canceled until the problem is resolved. You will be updated as pertinent information becomes available.

6. Promoting an Effective Management Style. The following entry shows the use of the public mode to confirm private communications giving a number of participants a specific time allocation:

[516] Kennard 2-Mar-76 12:46 PM
Ippolito, Kaiser, Nunnally, Miller. Time allocations for the week of 3/7-3/13 follow by private message. Please let me know any corrections promptly.

Notice that the whole group is now informed that four experiments have been allocated time (although exact times are not made public). The two groups made effective use of the system in classical management tasks, such as communicating information, requesting data, giving assignments, and making sure deadlines were met. Such use is apparent in the following entry:

[317] Hall 28-Jan-76 9:33 AM
For the record, Mascy's questions of yesterday discussed by phone. Reports 2 and 8 and parts of 7 and 1 will be mailed in the next 3 days. As previously suspected, report 9 will be late (and won't reach Spaeth by next Wednesday). Berkeley or PHM will mail report 5 this week. To repeat: report 8 was never intended to be "the" final report. See proposal, contract, and Admin. Report #2.

7. Extending Communications beyond Working Hours. Figure 4 shows the distribution of conferencing sessions as a function of time of day. It can be seen that 36 percent of all sessions occurred outside of West Coast working hours. Of special significance to NASA is the expansion of the narrow "telephone window" between the East and West Coasts. This greater flexibility in the use of time was noted by one participant in the transcript:

[173] Mascy 7-Jan-76 9:46 AM
. . . Just in passing, I noted the timeline of message 171 at 6:40 PM PST and message 172 at 5:25 AM PST . . . for what it is worth, the computer terminals have opened up the communications day to about 12 to 13 hours. . . . This might be compared to telephone day between East and West Coast of about 3 or 4 hours. . . .

Over 55 percent of all sessions took place outside the normal telephone windows.

EVALUATION OF USER ATTITUDES

In computer conferencing, as with all other media, one needs to assume that the participants have mastered the basic skills required to use the

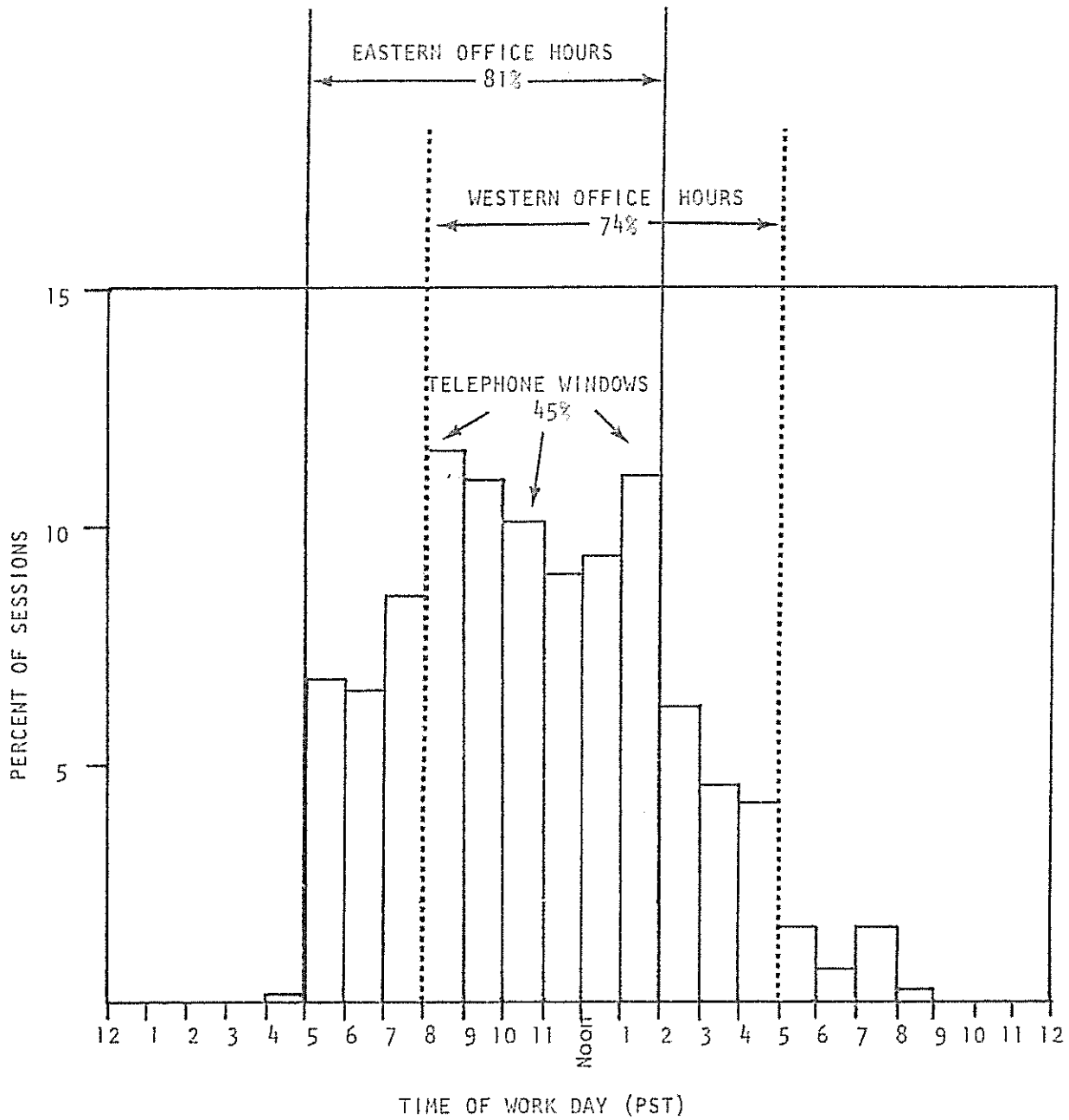

Figure 4. Distribution of Sessions as a Function of Time of Day

system before any meaningful evaluation can take place. Most of the participants in the two conferences described here developed the required skills in a short time. The lack of typing skills did not prove to be a barrier as was initially anticipated by some. Users developed definite opinions on the variety of tasks which they had to perform during the conferences. Among the tasks which were rated positively were: administrative activities; logistic and scheduling tasks; exchanges requiring short-term (but not immediate) response; very specific, narrowly-defined issues; quantitative information transfer; and routine day-to-day communications. The ability to perform these tasks by leaving or retrieving messages at their convenience was, by far, the most important feature of the medium for them.

Users agreed that the use of this medium for synchronous conferencing (with more than two or three other persons) headed the list of the negative uses. Tasks not well suited to the medium included: substantive debates, especially when experts disagree; broad issues; getting to know each other; situations which require immediate responses (responses depend on how frequently one accesses the system, and questions can be ignored via this medium just as by mail or telegram; however, the final transcript will document the question and the time when it was asked).

Users also agreed that computer conferencing replaced much telephone traffic. There was a general consensus that it reduced mail exchanges and saved some travel. However, PLANET was seen as more than a substitute for other media. With one exception, users believed that PLANET made a unique and beneficial contribution, which could not have been made by any other medium or combination of media, to the efforts of the group. Thus, computer conferencing was a supplement to existing communication modes as well as a substitute for certain kinds of communication.

In summary, the three most important values of the system were: its time *independence*, the availability of hard copy, and the ability to enter one's message without being interrupted. Aside from the negative response to synchronous conferencing, user reactions ranged from somewhat positive to very enthusiastic. Use did not lead to mechanistic exchanges nor did respondents feel overwhelmed by information (although some felt burdened

by irrelevant or trivial exchanges that they were forced to scan in order to extract information). Specific reactions to the PLANET system were similarly generally positive, notwithstanding the suggestions offered to make the system more responsive to the needs of these users.

COST CONSIDERATIONS

The cost of computer conferencing is an important variable in the evaluation of the potential use for the medium, and reliable information is becoming available as real-world usage of systems like PLANET are reported by participants. Six major components* should be considered, both in computing current costs and projecting future costs of a computer conference:

1. Terminal Equipment. It is possible to rent or lease terminals from manufacturers and from the networks. As the use of computer conferencing becomes more common, the cost of terminals can be spread among more users and more projects; it is expected that, within five years, terminals will become an overhead item (like a typewriter or a telephone) at most research institutions. This component of the cost will thus tend to decrease.

2. Communication with a Network Port. The cost of accessing the network may be quite significant to users outside of metropolitan areas served by commercial networks. The geographic coverage of the major networks is expanding rapidly, however. In addition, future technology could eventually make networks available to rural areas. This cost component, too, may thus decline in importance in years to come, although changes in telephone rate charges complicate the projection.

3. Network Connection. Since network connection is the largest component of the conferencing cost, the connect time rate must decrease

*These do not include considerations of participant salaries, editing of transcripts, and royalty on the use of a program package (not applicable here, but to be taken into account with future commercial systems). Nor do they include the costs of training and facilitation, which should also be considered at some point.

dramatically in order for teleconferencing to make a commercial breakthrough. Network rates are expected to decrease slowly with more efficient technology for message or packet processing.

4. Computer Utilization. The use of the computer is billed according to the number of "resource units" used in a given session. In the future, more efficient time-sharing systems, an expanded number of ports into the computer, and the use of mini- or microprocessors will decrease the cost of computing, possibly by more than 50 percent in 1980.

5. Storage. A conference is a file that resides on a mass storage device. Average costs are 32 cents per "block" of 624 characters, or 50 cents per 1,000 characters.

6. Administrative Overhead. The bill received by the user from the network each month covers not only the computing and connection charges but also a number of other items, such as:

- a flat charge for each user name;
- a charge for special handling of tapes or cards and the runs of the monitor program that computes and lists the statistics; and
- session overhead, representing the amount of computer resources used to log-in and to load the PLANET program.

The need for the computer supplier to break even on the use of the system will demand that storage and administrative charges remain significant. However, there is still room for improvement with larger, less expensive memories and more efficient handling of user accounts and secondary services. One should keep in mind that when conferencing usage spreads, the files holding the discussions will become much larger than anything currently observed, distorting many usage patterns.

Finally, a few words should be said about facilitation. It is easy at this point to fall into a familiar pitfall, planning future computer conferences on a purely economic basis. In our view, the much larger question of training and facilitation must be included in such a plan from the beginning. This aspect is so critical to the success of the medium that it must not be swept under the rug of budgetary convenience.

If participants are to solve real-world problems through computer conferencing and if the organizations to which they belong are to pay for their usage of the system with real money, a continuous structure must be provided for learning and facilitation activities. Such a structure cannot be improvised for each conference, nor can it be expected to arise naturally among a group of users. It should be provided from the start. Not only do new participants need training in the use of the system, but group leaders require continuous guidance. The conference as a whole must be nurtured by someone who may not be a substantive contributor but who offers a rich set of social skills. Such facilitators should ideally belong to the same organization as the conference participants. But they, too, need to be trained. A new role is thus emerging as we consider future communications situations.